

Smart Home Networking

Deepak Gupta

Department of Computer Science Engineering
Poornima College of Engineering
Jaipur, India

Shakshi Mishra

Department of Computer Science Engineering
Poornima College of Engineering
Jaipur, India

Abstract—Smart Home technology is the integration of technology and services through home networking for a better quality of living. Home networking is called as Digital Home Network. It means that PC, home entertainment equipment, home appliances, Home wirings, security, illumination system were communicated with each other by some composing network technology, constitute a networking internal home, and connect with WAN by home gateway. This paper reviews the definition of smart home and the details of smart home elements including smart home networks that can be classified into two main types, which are wiring system and wireless system, smart home controllers that use for managing system, the appliances or the smart devices and the challenges of smart home.

Keywords-Home network; smart home; home appliances; home gateway

I. INTRODUCTION

Many human activities in modern age are now based on usage of the Internet, which interconnects many people and things around the earth. A smart home is a home equipped with its own network system which connects all the devices and things in the home. This network is called a home network.

A smart home is understood as an integration system, which takes advantage of a range of techniques such as computers, network communication as well as synthesized wiring to connect all indoor subsystems that attach to home appliances and household electrical devices as a whole. In this way, smart home techniques enable households to effectively centralize the management and services in a house, provide them with all-round functions for internal information exchange and help to keep in instant contact with the outside world. In terms of convenience, they help people in optimizing their living style, rearranging the day-to-day schedule, securing a high quality of living condition and in turn enable people to reduce bills from a variety of energy consumptions in a house.

II. HOME NETWORKING TECHNOLOGY

Smart home network technology can be classified into two main types, which are wiring system and wireless system. In wiring system, the equipment will be connected into the main power supply directly, so the data will be sent to the devices to activate or deactivate them. In the wireless system, there must have two main elements that are sender and receiver. Many new appliances use wireless technology to communicate with other devices. The example of wireless communication system

are microwaves, Infrared (IR), radio frequency (RF), Wi-Fi, Bluetooth, IEEE802.11, and so on.

A. *Wired technology*

Phone line: PhoneLine or HomePNA networking works over the existing copper telephone wires in your home without interfering with voice or DSL communications uses the same basic transmission technology as traditional Ethernet .Several issues that need to be addressed before the success of phone line-based home networking systems are guaranteed. These include:

- **Random Wiring Topologies:** Rather than the hub structure of business networks, the Home phone line wiring system is a random “tree,”
- **Signal Attenuation:** The random tree network topology of a phone line wiring system can cause signal attenuation. In simple terms, attenuation means a reduction of signal strength during transmission of data across the home network. The attenuation on a phone line network is normally caused by open plugs and un-terminated appliances.
- **Signal Noise:** Appliances, heaters, air conditioners, consumer appliances, and telephones can introduce signal noise onto the phone wires.
- **Telephone Jacks:** Phone jacks are not found everywhere in the home. The physical location of those jacks with respect to the devices that need to be networked is another problem.

Power line: Powerline Carrier Systems (PCS) is a technology which is used to send coded signals along a home's existing electric wiring to programmable switches, or outlets. These signals convey commands that correspond to "addresses"

or locations of specific devices, and that control how and when those devices operate. A PCS transmitter, for instance, can send a signal along a home's wiring, and a receiver plugged into any electric outlet in the home could receive that signal and operate

LONWORKS (Local Operation Networks): The LonWorks technology, developed by Echelon and it is a general purpose control network technology that can be used to

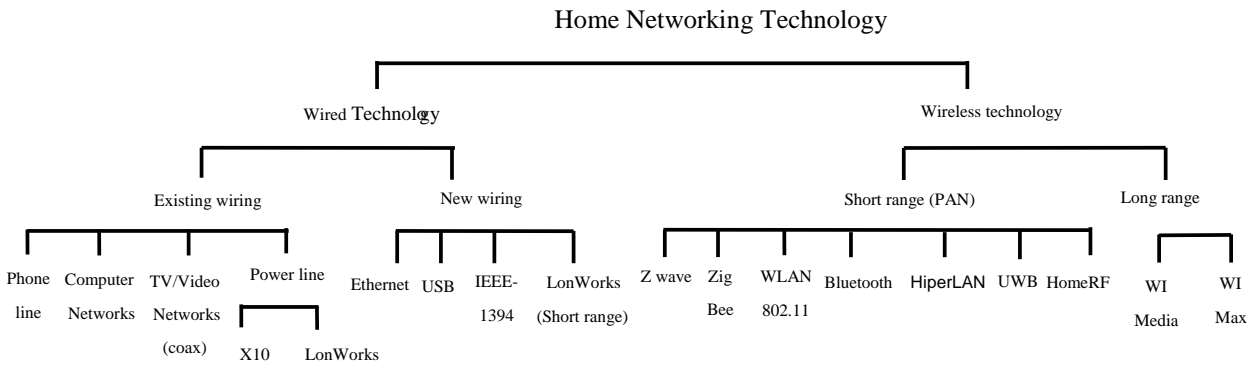

Fig.1: Home Networking Technologies Subdivisions

the appliance to which it is attached. Power line Based Applications in Home Networking:

- Lighting Control
- Temperature & Ventilation Control
- Security
- Sprinklers
- Audio/Video Control
- Sensors
- Gates & Doors Control
- Pool & Spa Control
- Phone Control
- PC Control

X-10: X10 is a common protocol for PCS, it is a signalling technique for remotely controlling any device plugged into an electrical power line. X10 signals, which involve short radio frequency (RF) bursts that represent digital information, enable communication between transmitters and receivers. The X10 modules are adapters connected to outlets and controlling simple devices. X-10 transmission rate is limited to only 60 bps which makes it unsuitable for carrying internet type traffic around the house.

Ethernet: Ethernet is the most popular home networking, Ethernet networks operate at 10Mbps to 100Mbps within a range of 500 feet. They can be as simple as two computers with NICs connected with a cable or as complex as multiple routers, bridges and hubs connecting many diverse network appliances.

monitor sensors and control outputs in a wide variety of applications.

A control network is any group of devices working in a peer-to-peer fashion to monitor sensors, control actuators, communicate reliably, manage network operation, and provide complete access to network data. The LonWorks technology is comprised of following major elements:

- Neuron Chip control processors and transceivers
- LonTalk communication protocol
- LonWorks Network Services (LNS)

B. Wireless technology

Z-Wave. Z-Wave uses a Source Routing Algorithm to determine the fastest route for messages. Each Z-Wave device is embedded with a code, and when the device is plugged into the system, the network controller recognizes the code, determines its location and adds it to the network. When a command comes through, the controller uses the algorithm to determine how the message should be sent. Because this routing can take up a lot of memory on a network, Z-Wave has developed a hierarchy between devices: Some controllers initiate messages, and some are "slaves," which means they can only carry and respond to messages.

ZigBee. ZigBee's name illustrates the mesh networking concept because messages from the transmitter zigzag like bees, looking for the best path to the receiver. While Z-Wave uses a proprietary technology for operating its system, ZigBee's platform is based on the standard set by the Institute for Electrical and Electronics Engineers (IEEE) for wireless

personal networks. This means any company can build a ZigBee-compatible product without paying licensing fees for the technology behind it, which may eventually give ZigBee an advantage in the marketplace. Like Z-Wave, ZigBee has fully functional devices (or those that route the message) and reduced function devices (or those that don't).

Local Area Networks (WLAN, 802.11): operate at 2.4GHz or 5 GHz ISM bands and offer speeds up to 54 Mbps. They support two modes: ad-hoc and infrastructure. The ad-hoc mode allows stations to spontaneously form a wireless LAN, in which all stations communicate with each other in peer-to-peer manner. The infrastructure mode, the network has an access point (AP), through which each client station communicates. WLAN may not be applicable for wireless device-to-device communication because of high power consumption, requiring line power or power over Ethernet. The expense of providing the power lines may limit the size of the network.

UWB: is a short-range technology based on transmission of impulses lasting only fractions of nanoseconds emitted in periodic sequences. IEEE 802.15.3 specification defines the physical layer for UWB. also a Radio Frequency (RF) technology that transmits binary data, using low energy and extremely short duration impulses or bursts (in the order of picoseconds) over a wide spectrum of frequencies. It delivers data over 15 to 100 meters and does not require a dedicated radio frequency.

Bluetooth: Bluetooth, promoted by the Bluetooth Special Interest Group (SIG), provides a comparably low-cost solution wireless communication among portable or handheld devices at a maximum data rate of 1Mbps within up to 10 meters. In order to avoid interfering with other protocols which use the same frequency, Bluetooth uses frequency-hopping technique. It divides the band into 79 channels (each 1 MHz wide) and changes channels up to 1600 times per second.

WiMedia: range 7.5 GHz frequency divided into 5 band groups with 14 sub-bands.

WiMax: (Worldwide Interoperability for Microwave Access) that is largely based on the wireless interface defined in the IEEE 802.16 standard. Designed to deliver next generation, high-speed mobile voice and data services and wireless backhaul connections that could potentially displace a great deal of existing radio air network (RAN) infrastructure. Also it is a new wireless technology which provides Mobility, Coverage, Maintainability; Roaming Services etc. WiMax network provides accurate proficiency in telecommunications and latest technology of hub and routers to get best result during broadcasting. WiMax services make available a customized network for home.

Insteon: Using a wireless network provides more flexibility for placing devices, but like electrical lines, they might have interference. Insteon offers a way for your home network to communicate over both electrical wires and radio waves, making it a dual mesh network. If the message isn't getting through on one platform, it will try the other. Instead of routing the message, an Insteon device will broadcast the message, and all devices pick up the message and broadcast it until the command is performed. The devices act like peers, as opposed to one serving as an instigator and another as a receptor. This means that the more Insteon devices that are installed on a network, the stronger the message will be.

Differentiator	Structured wiring				Existing wiring				Wireless						
	<i>Ethernet</i>	<i>USB 2.0</i>	<i>IEEE -1394</i>	<i>LonWorks</i>	<i>Phone line</i>	<i>Computer networks</i>	<i>Coax</i>	<i>Power line</i>	<i>Zwave</i>	<i>Zig Bee</i>	<i>WLAN 802.11</i>	<i>Bluetooth</i>	<i>UWB</i>	<i>Wi media</i>	<i>Wi max</i>
Best uses	New construction and remodelling				Interconnecting stationary				Mobile devices such as laptops, palmtops and web pads						
Cost	High for installation				Low				Low						
Useful lifetime	Very long				Relatively short		Medium		Short						
Number and location of outlets	Wherever needed				Multiple electrical outlets in every room; many rooms with telephone outlets; few rooms with coax outlets				Ideally throughout the home						
Maximum Current data rate (Mb/s)	100	480	800	100	160	1-14	100	30-60	100	250 Kbps	54	2.1	480	53.3 to 480	15
Maximum Future data rate (Mb/s)	1000 Mbps	5Gb/s	1000 Mbps		30-250 Mbps				100	250 Kbps	300Mbps	24Mbps	1.6 Gbps	280 Mbps	40
Security	High secure				Less secure		High secure		Less secure						
Standardization	Well-defined global standards				Competing standards				Competing standards						
Operating Frequency band	600 MHz	5GHz	800	100 MHz	4 to 10 MHz	100M Hz	100M Hz	500KHz	2.4 GHz	2.4 GHz	5 GHz	2.4 GHz	10.6 GHz	7.5 GHz	5.8 GHz

III. HOME NETWORKING DEVICES

There are all kinds of devices in a home network. They play different roles, but all of them are indispensable to support human beings' daily life.

- 1) Network devices: In order to connect various devices, it is necessary to use some network devices like router, adapter, bridge, connecting hub, etc.
- 2) Computing devices: In a home network, a family member may use a desktop personal computer (PC), a notebook, a tablet computer, a mobile phone, and a smartphone for various purposes through using their computing power.
- 3) Sensor devices: It is useful to deploy multiple kinds of sensor devices to obtain various information. Human-body-related sensors are indispensable to collect data for healthcare services.
- 4) Home appliances: There are many kinds of home appliances in a modern smart home, and it is very desirable to connect these appliances to a home network for operation, maintenance, and other purposes. Historically, each home network was developed for home appliance management. It is becoming popular to control air conditioners from outside a house using mobile phones.
- 5) Media service devices: There are multiple media devices to handle audio/video recording and playing. The screen has become high definition, and sound has become multidimensional. People can enjoy a home theatre through these high-quality media devices. It is necessary to implement high-bandwidth communication channel for these purposes.
- 6) TV/radio devices: TV and radio broadcasting is very popular and is inevitable in our modern life, and so it is necessary to connect TV equipment to a home network.
- 7) Security devices/disaster prevention devices: A home network can be used to make a smart home safe. Multiple cameras for security and multiple motion sensors located at windows and entrances can be connected together through a home network, and an alarm control security system can detect automatically any invasion. It is also possible to use natural disaster detection devices for major earthquake detection. Early detection of a big disaster may help human beings take action and move to safer areas.
- 8) Power-related devices: There has been a strong concern to control the power consumption of a smart home, and home power management systems, such as the home energy management system (HEMS), have appeared recently. Such a system can be connected to the home network of a smart home, and an efficient ecological operation can be achieved. It is possible to install a battery and a solar panel in a smart home, and its management system can be connected to a home network to enable a total energy management.

IV. HOME NETWORKING PROTOCOLS

It is necessary to have various software functions and packages to operate a home network in a systematic way. Well-designed protocols are essential. In the initial stages of a home network development, network systems have been naturally Internet oriented, and there have been several standardized protocol systems developed as follows.

- 1) Universal Plug and Play (UPnP) Forum : UPnP defines the protocol system to connect devices to the network instantly.
- 2) Ubiquitous Open Platform Forum(UOPF): This is supported by the Japanese Forum for Internet Service Provider and home appliance companies, and its purpose is to connect digital home appliances to the Internet easily.
- 3) Digital Living Network Alliance (DLNA): This is supported by many digital home entertainment makers and mobile PC or phone makers, and its purpose is to construct the common guidelines for easy networking between these devices in a home network. It is based on the UPnP and the Hyper Text Transfer Protocol (HTTP). There are many digital home devices which are certified for these guidelines.
- 4) Open Service Gateway Initiative (OSGi): OSGi Alliance defines a Java-based service platform, which is controlled remotely through a network. Based on this platform, service software has been developed, and service registry has service programs that are controlled remotely.
- 5) ECHONET: ECHONET is a standard developing consortium in Japan, and defines a smart house concept based on energy saving, energy accumulation, and energy generation.
- 6) P2P Universal Computing Consortium (PUCC): PUCC developed standards which enable connection among devices in different kinds of networks. It defines overlay protocols to connect devices in different kinds of networks.

It is possible to develop real service applications using the above protocol systems and platforms. Home theatre entertainment, healthcare service, security service, elder people support service, energy management service, natural disaster prevention service, and so on are possible examples of a smart home. With the devices and home networks having more and more elaborated functions, it is now possible to support at-home business development or children studying in a smart home.

V. HOME GATEWAY

A special dedicated network node in a home network, called HGW. It connects a broadband public service network and the home network in a smart home. HGI has been developing specifications for HGW standard architecture. Home network includes a hierarchical network scheme to connect various kinds of devices, and HGW connects this home network to the Internet service through a broadband public provider. PAN/BAN network schemes such as Bluetooth or ZigBee need

a corresponding network adapter, and HGW may be equipped with these adapters.

There are some specific services provided by service providers outside a smart home, and HGW is a good relay point to support these kinds of communication services. These services include TV broadcasting, IP telephone, network gaming, and so on, and need a high-bandwidth communication channel.

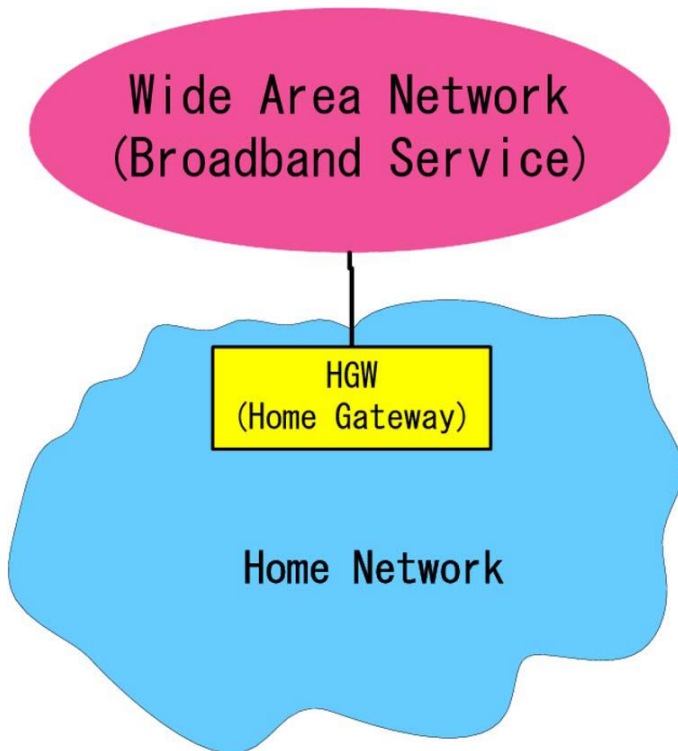

Fig2: Home gateway

VI. CONCLUSION

This paper reviewed different types of networking technologies suitable for smart home applications and compared between them regarding their uses, cost, security, transmission range and their advantages and disadvantages.

Service application systems are provided through the Internet, and a user in a smart home uses these application systems through HGW. Some of them need data from several devices in the home network, and these application systems require smooth cooperation with HGW.

People who are elderly or disabled benefit the most from a home automation system that employs artificial intelligence. These systems offer those who are less mobile, or in delicate health, the opportunity to be independent, rather than staying in an assisted living facility. Designing a Smart Home is also very crucial.

REFERENCES

- [1] Cuizhi Chang, "Design of Home Gateway based on Intelligent Network", 2008 IEEE Pacific-Asia Workshop on Computational Intelligence and Industrial Application
- [2] Nobuo Saito, "Ecological Home Network : An Overview", Proceedings of the IEEE | Vol. 101, No. 11, November 2013
- [3] Meensika Sripan, Xuanxia Lin, Ponchan Petchlorlean and Mahasak Ketcham, "Research and Thinking of Smart Home Technology", International Conference on Systems and Electronic Engineering (ICSEE'2012) December 18-19, 2012 Phuket (Thailand)
- [4] Armando Roy Delgado, Rich Picking and Vic Grout, "Remote-Controlled Home Automation Systems with Different Network Technologies", Centre for Applied Internet Research (CAIR), University of Wales, NEWI, Wrexham, UK
- [5] Farouk AbdAllah Salem, Heba kamal sheasha, Mohamed El-Habrouk, "A Survey of Smart Homes Technologies", Proc. of the Intl. Conf. on Advances in Electronics, Electrical and Computer Science Engineering— EEC 2012
- [6] Jin Cheng and Thomas Kunz, "A Survey on Smart Home Networking" Carleton University, Systems and Computer Engineering, Technical Report SCE-09-10, September 2009"